



# Control Valves General Catalogue



Continuously Improving  
Flow Control





“Engineering the Future”

# Our vision of the future

Operators in the energy industry are continually requested to increase production, operate at higher pressures, higher temperatures, deeper waters and to deal with increasingly corrosive fluids.

The valves which are vital components in the process, are requested to perform critical functions in these demanding conditions.

Meeting the highest quality standards and anticipating new and future market demands, our mission at PIBIVESSE is “Engineering the Future”, supported by the latest technologies we develop and provide new products tested simulating the working conditions.











# Contents

<b>Circor International Group Overview</b>	<b>6</b>
<b>The Company</b>	<b>7</b>
<b>Severe Service Control Valve Solution</b>	<b>8</b>
LNG - GTL	
Oil & Gas	
Power generation	
Refining - Petrochemical	
Water transmission & desalination	
<b>Rotary Control Ball Valve Solutions</b>	<b>9</b>
Innovative concept	
Smaller Overall dimension	
<b>Rotary Control Technology</b>	<b>10</b>
Rangeability	
Trim versatily	
Long service life	
Dynamic torque	
<b>Control Valve Solutions</b>	<b>11</b>
Cage Ball concept	
Hyper cage	
Hyper silent	
<b>Product Overview</b>	<b>14</b>
<b>Calculation Program</b>	<b>16</b>
SimOne	
Flow Lab	
<b>Quality Assurance System</b>	<b>17</b>
<b>A World of Servicing</b>	<b>18</b>
<b>Reference &amp; Application</b>	<b>18</b>

# CIRCOR. International Group Overview

CIRCOR International designs, manufactures and markets valves and other highly engineered products and sub-systems used in the energy, aerospace and industrial markets.

- Culture focused on talent and continuous improvement
- Global presence that operates primary manufacturing facilities located in the United States, Canada, Western Europe, Morocco, India, Brazil and the People's Republic of China

- Comprised of 3 reporting segments: Energy, Aerospace and Flow Technologies

- Products sold through over 950 distributors
- Service over 7,000 customers in 100+ countries around the world

As our global infrastructure continues to evolve, we are committed to accelerating the growth of our businesses, our customers' businesses, the infrastructure markets we serve, and our peers every day.

Brands	Markets
<b>ENERGY</b>	
<ul style="list-style-type: none"> <li>• Contromatics</li> <li>• Hydroseal</li> <li>• KF Valves</li> <li>• Mallard</li> <li>• Pibiviesse</li> <li>• Pipeline Engineering</li> <li>• Sagebrush</li> <li>• SF Valvulas</li> </ul>	<p>CIRCOR Energy is a market-leading, global provider of integrated flow control solutions in the expanding and evolving oil and gas industries, specializing in highly engineered valves and pipeline products and services.</p>
<b>AEROSPACE</b>	
<ul style="list-style-type: none"> <li>• CIRCOR Aerospace, Inc.</li> <li>• Aerodyne Controls</li> <li>• Bodet Aero</li> <li>• Industria S.A.S.</li> <li>• Motor Technology</li> </ul>	<p>CIRCOR Aerospace is a growing industry leader with primary focus areas of fluid controls, actuation systems, landing gear systems, pneumatic controls and electro-mechanical controls.</p> <p>Circor Aerospace sub-systems, components and products are flying on most commercial and military aircraft, including single and twin-aisle air transport, business and regional jets, military transports and fighters, and commercial and military rotorcraft. Other markets include unmanned aircraft, shipboard applications, military ground vehicles and space.</p>
<b>CIRCOR FLOW TECHNOLOGIES</b>	
<ul style="list-style-type: none"> <li>• Cambridge Fluid Systems</li> <li>• Circle Seal Industrial</li> <li>• CIRCOR Tech</li> <li>• CPC Cryolab</li> <li>• Dopak Sampling</li> <li>• GO Regulators</li> <li>• Hale Hamilton</li> <li>• HOKE-GYROLOK®</li> <li>• Laurence</li> <li>• Leslie Controls</li> <li>• Nicholson Steam Trap</li> <li>• Rockwood Swendeman</li> <li>• RTK</li> <li>• Spence Engineering</li> <li>• Texas Sampling Systems</li> </ul>	<p>CIRCOR Flow Technologies is a global enterprise comprised of market leading brands that collectively offer a broad range of flow control capabilities for difficult applications including cryogenic, high pressure steam, corrosive media and ultra-pure fluid handling.</p> <p>Some of these highly engineered, often mission-critical systems and products are brands that have been serving the market for over 50 years including CSC Industrial, CPC Cryolab, Hale Hamilton, Hoke, Spence Engineering and for Leslie Controls over 100 years.</p>
<p><b>Executive headquarters:</b> Burlington, MA</p> <p><b>Sales and manufacturing facilities in:</b> United States, Canada, Italy, Germany, France, England, The Netherlands, China, India</p> <p><b>Employees:</b> 3,000 Worldwide</p>	

## The CIRCOR Difference = CIRCOR Business System

The driving force behind what enables CIRCOR to accelerate growth for our businesses, customers and the industries we serve every day is the CIRCOR Business System.

The CIRCOR Business System is defined by our commitment to attracting, developing and refining the best talent, and pursuing continuous improvement in all aspects of our business and operations. The CIRCOR Business System promotes improved shareholder value through a commitment to six (6) core competencies across all of our business units.

1. Lean Enterprise, Six Sigma & Continuous Improvement
2. Talent Acquisition, Development & Retention
3. Acquisition Integration & Repositioning
4. Global Manufacturing & Supply Chain Management
5. Global Business Development
6. New Product Innovation

Utilizing the CIRCOR Business System has enabled us to leverage our high-performance, lean operations to grow globally; tie our supply chain directly to our customers' demands; acquire strategic businesses that expand our capabilities in mature and emerging markets; refine and improve our ability to forge meaningful customer relationships; and achieve significant advances in product innovation.



# The Company

## History

PIBIVIESSE was established in 1981 by three partners, combining the forgemaster expertise with the experience in valve design, manufacturing and marketing. The vision of the future was to design and manufacture state-of-the-art valves “designed to perform – built to last” for the most demanding applications. Their commitment was to follow a “total quality” concept, from quotation to field service, without any compromise. The “Total Quality” concept proved to be so successful that the company rapidly became a world-class, highly appreciated soft and metal seated ball valve manufacturer, for many applications in Oil &



Gas and other related industries, including Offshore platforms and Sub-sea applications. In 1985 and 1989 PIBIVIESSE carried out a series of acquisitions of companies with a long experience in machining ball valve components, in order to expand its manufacturing capacity.

In 1994 Watts Industries Inc. acquired PIBIVIESSE and a new plant of more than 12,000 sq m (132,000 sq ft) covered area was built in Nerviano, about 20 km north-west of Milan, where the head office and main production activities were transferred. A new building of further 3,400 sq m (38,000 sq ft) was added in 1997, to increase capacity for heavy duty machining and valve assembly. In 1998 CIRCOR International Inc, current PIBIVIESSE parent Company, was spun-off from Watts Inc.

A second generation of proprietary technology valves was developed in 2000, called CAGEBALL™.

These revolutionary control valves, designed for extremely severe working conditions, set a step change not only in PIBIVIESSE but also in the flow control market, allowing combinations of valves sizes and flow conditions well beyond industry standards.

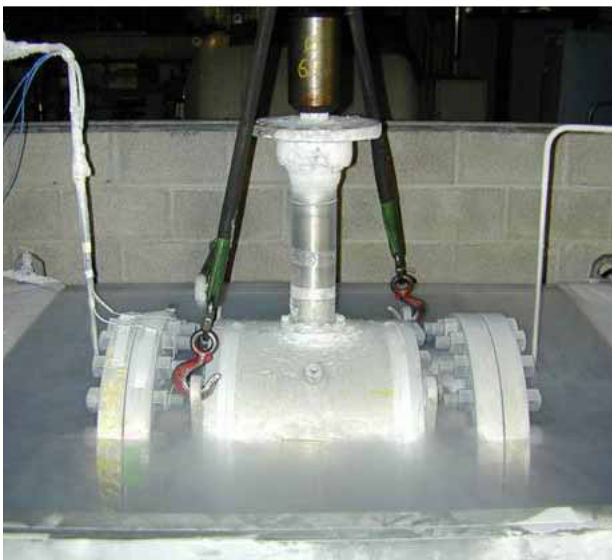



# Severe Service Control Valve Solution

## for Gases, Liquid and Multi-phase Fluid



### LNG - GTL

- Anti-surge recycle
- Cryogenic application
- Flow pressure control
- Feed gas flow control
- Gas-to-flare blowdown
- Hot & cold gas compressor bypass
- Line depressurizing
- Refrigerant level control
- Gas storage



### Oil & Gas

- Loading arms flow control
- Pumps and systems start-up
- Depressurization
- Gas to flare
- Metering and mixing stations
- Gas booster stations
- Transmission lines
- Compressor control



### Power Generation

- Steam dump to condenser
- Turbine by-pass to condenser
- Cooling water
- Steam venting
- Pressure reduction (prv)
- Geothermal applications
- Main steam pipe drain valve
- Cond. Pump recirculation valves
- Deareator level control valve
- Feedpump recirculation valves
- Start-up feedwater control valves
- Feedwater heater drains
- Boiler start-up drum control valves
- Flow balancing control valve
- Gas / oil burner supply



### Refining/Petrochemical

- Blow-down and venting
- Catalysts handling
- Compressor anti-surge
- Flow control - tight shut-off (isolation)
- Fuel gas control to burners
- Cooling water



### Water Transmission & Desalination

- Pumping station flow control
- By-pass control
- High mass flow noise control
- Cavitation control
- Brine heater control
- Reversed osmosis control



# Rotary Control Ball Valve Solution

## Innovative Technology for Total Control

High differential pressure ( $\Delta P$ ) applications have historically been controlled by the vertical rising operation of a globe valve. As process plants have increased throughput, operating pressures and temperatures, many linear globe valves have become unreliable and unstable. Problems such as high friction, shaft wind-up, erosion and vibration have been associated with linear globe control valves. The continuous vertical movement of the stem leads to a deterioration of stem packing and may cause dangerous stem leaks. Stem packing integrity is essential to reduce emissions of volatile organic compounds or gases.

A rotary control ball valve is inherently the best choice with its quarter-turn radial operation, straight-through conduit bore and tight shut-off. The rotary action versus the linear operation is not prone to stem wear and is suitable for a high number of cycles. **Using a quarter-turn ball, provides a quick and/or easily maintained response time.** The Pibiviesse technology expands the standard strengths of the ball valves adding the capabilities of **precise modulation**, exceptionally **high rangeability** and **characterization**.

## MAIN FEATURES

- *Smaller envelope*
- *Less weight*
- *Greater installation flexibility*
- *Reduce material and infrastructure costs*
- *Piggable version*
- *Longer stem seal life*
- *Less emissions*
- *Large rangeability*

## Smaller Envelope Size Saves Money

Even when globe valves have been engineered to cope with today's plant operations, because of their linear operating design, the valves have considerably increased their dimensional envelope, adding material and infrastructure costs. The rotary control valve with PBVS technology has a **smaller overall dimensional** envelope than a traditional linear control valve, which reduces costs associated with valve construction, piping layouts and materials. This **more compact design** allows for **bottom line savings** that can be repurposed for other plant needs.



*As demonstrated in this illustration, the overall dimensional envelope of the PBVS valve is much smaller than the size of a typical globe valve-yet delivers equal rates of Cv.*

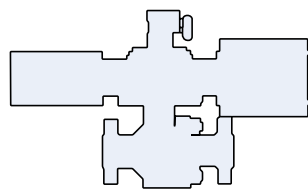

12 INCH CAGEBALL ANSI 600#  
CV= 5200

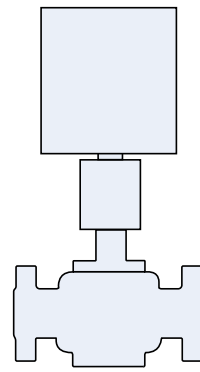

16 INCH AXIAL VALVE ANSI 600#  
CV= 5000

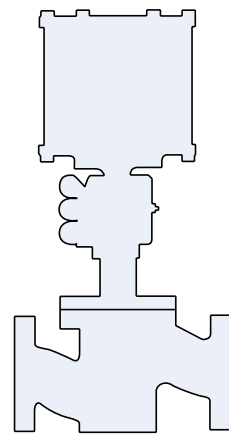

24 INCH GLOBE VALVE ANSI 600#  
CV= 5000



# Rotary Control Technology

## Rangeability

The rangeability is greater than 500:1. The rangeability is limitless by providing a control trim element at flow conditions only where it is necessary. The rest of the ball flow passage can be left open to provide a low-pressure let down, high-capacity opening.

## Trim Versatility

Based on the Pibiviesse valve body cavity design, the control trim is interchangeable. If the valve Cv needs adjustment, a new ball with new flow characteristics can be placed within the existing valve body. This allows for a reduction in spare parts inventory.

## Long Service life

Solid metal seat construction provides long service life in demanding applications. The constant wiping action of the seat across the ball's sealing surface prevents scale and sludge buildup, and provides excellent service on steam, gases, slurries and various liquid applications.

## Dynamic Torque

Under differential pressure conditions the flow tends to open or close the valve. This is caused by asymmetric pressure distribution on the internal surface of ball. This has to be taken into account when selecting the actuator. Cage ball balancing tails divide the dynamic forces evenly inside the trim internals and considerably reduce the dynamic torque.





# Control Valves Solutions

## CAGEBALL *Concept*

### Operation properties

Pibiviesse Cage-Ball control valves are enhanced second generation of control ball valve design. It is based on a changeable internal cage which divides the pressure drop in stages. The attenuating plates, mounted into a replaceable cartridge, are offset by an optimally designed angle to obtain a number of significant control advantages. Noise, cavitation and high frequency vibration are almost totally eliminated.

The turndown is increased to 250. The new balancing tails significantly reduce the dynamic forces generated by the attenuating plates. This balanced trim offers the following advantages: lower torques, increased accuracy, ease of operation and reduced load on the stem module. Extra large bearings can handle pressure, dynamic loads and vibrations ensuring they do not affect Cage-Ball valves performance. This guarantees stability during throttling operation.

### Application

Due to high flow factors as FL, Xt and Z along with exceptional flow capacity, Cage-Ball valves give optimal solutions in various severe control applications like: Flow control on loading arms (including topups) – Pumps and system start-ups – Partial throttling – Compressor control. By-pass on transmission lines – Surge relief – Smooth depressurizations – Equalization/balancing and venting. Blow-down (with reduced Hydrate formation) – Switching (where smooth transitions are required).

### Benefits

Benefits include economy in large mass flowrates, low noise and/or non-cavitating fluid handling, axial flow in large flow-rates also means lower turbulence, vibrations and balanced constant torque development. Smaller safety factors can be used when sizing actuators, meaning savings in actuator size, control accessories and air consumption.

### Options

These control valves can have reduced trim or expanded outlet equipped with integrated flow restrictor resulting in linear flow characterization or constant  $\Delta p$  over the valve.

In addition to a large choice of materials and seating arrangements, combined with full or reduced bore configurations the Cage-Ball control valves can be tailored to suit actual service conditions.

### Self cleaning

A new feature is the self-cleaning effect built in the trim design. When the valve is in large openings (this happens if the attenuating plates are plugged by dirt or solids that might be in the flowing medium) the angle between the flow axis and the plates is optimal to generate a depressurization behind the plates. This cleans the plugged holes and significant savings on maintenance can be achieved.

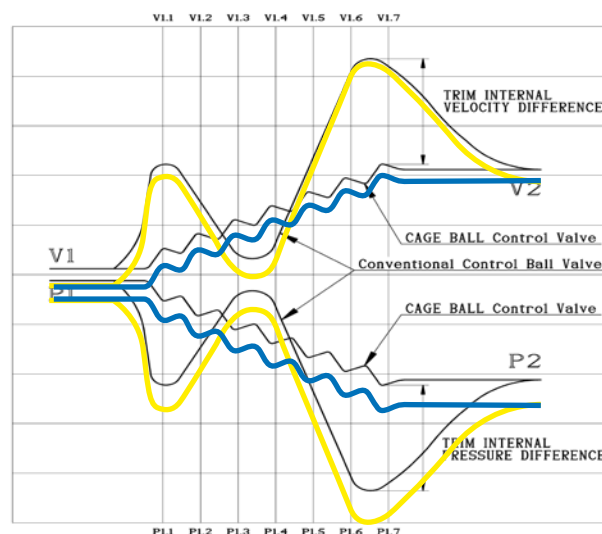
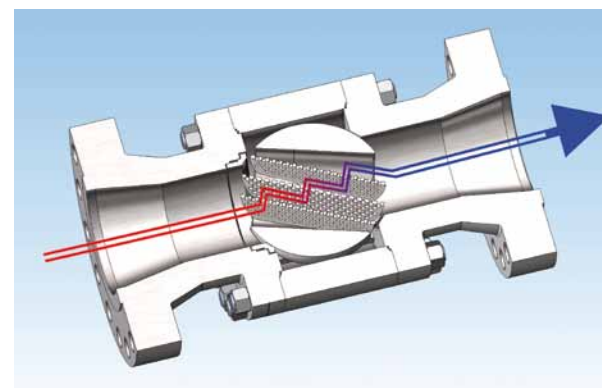
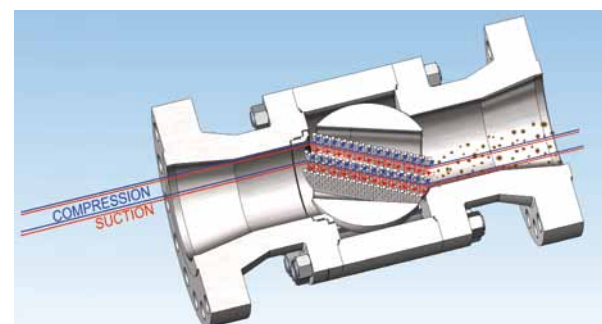
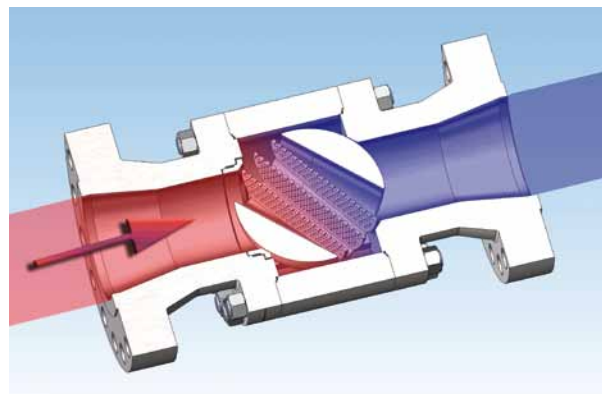

# Control Valves Solutions

## HYPER CAGE Trim Concept (patented)

### Operational properties and features of Hyper Cage-Ball control valves

In addition to the mechanical features of the Cage-Ball, this line of control valves is designed for all applications where extremely high pressure drops at fully open valves are required. The design combines the high efficiency of the multistage type trim with the Cv of a conventional ball valve that can be full or reduced bore. When the valve is fully opened, the Cv is equivalent to the full diameter of the pipe. A remarkable feature is that both the labyrinth and flow bore can be configured to suit the service condition and to determine the control range to reach over 400:1.

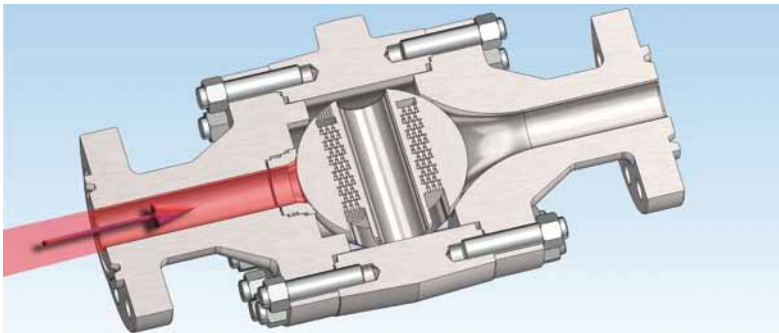

FULLY CLOSED

THROTTLING POSITION  
High pressure drop

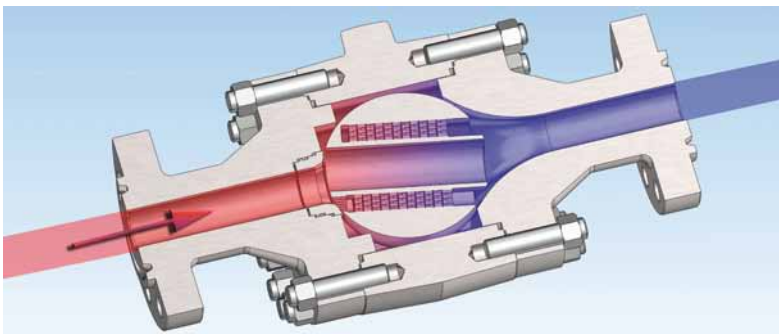
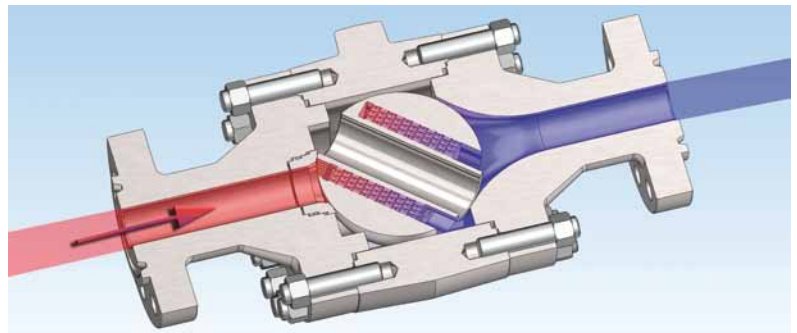

THROTTLING POSITION  
Low pressure drop

FULLY OPEN  
Zero pressure drop

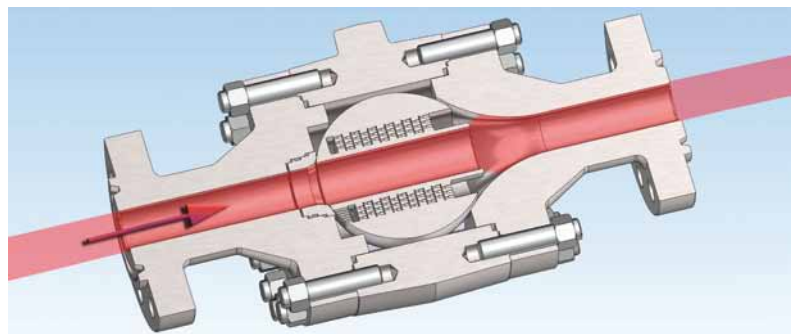



# Control Valves Solutions

## HYPER SILENT Cage Ball (patented)

Aerodynamic noise generation is a natural consequence of any gaseous flow through a control valve; the Hyper Silent Cage Ball valve is designed to reduce acoustic noise levels when using compressible fluids such as steam, air and gases and offers a unique concept of low noise level, with high capacity and excellent control properties.

Hyper Silent trim has been developed by Pibiviesse and provides a noise reduction at up to 35 dB (A) of generated noise inside the valve compared to normal low noise trim. The Hyper Silent trim design is simple and effective; a special soundproofing materials is sandwiched between two parallel perforated plates. Noise attenuation is achieved by specific hole geometry of the attenuator plate, which is the result of intensive computational and experimental studies.

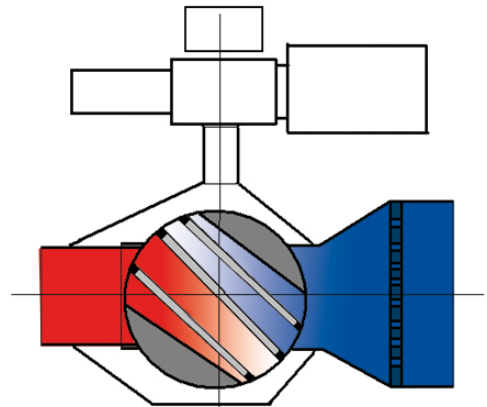

*HYPER SILENT TRIM WITH SOUNDPROOFING MATERIAL AND EXPANDED OUTLET WITH ORIFICE PLATE*



# Product Overview

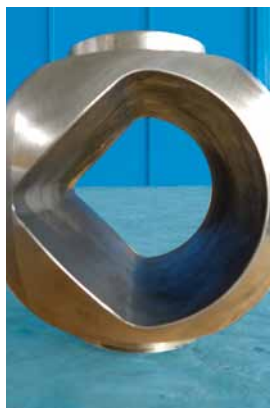

Model	Ball Control Valve	V-Ball	Uni Cage	Cage Ball
Design	Trunnion Mounted Full and Reduced Bore	Trunnion Mounted Full and Reduced Bore	Special CV Full and Reduced Bore	Critical application Full and Reduced Bore
Size Range*	1÷60" DN 25÷1500	1÷24" DN 25÷600	1÷6" DN 25÷150	6÷60" DN 150÷1500
Pressure Rating	ASME Class 150÷2500# API 10000÷20000	ASME Class 150÷2500# API 10000÷20000	ASME Class 150÷2500# API 10000÷20000	ASME Class 150÷2500# API 10000÷20000
End Connections	<ul style="list-style-type: none"> <li>• Flanged</li> <li>• Welded</li> </ul>	<ul style="list-style-type: none"> <li>• Flanged</li> <li>• Welded</li> </ul>	<ul style="list-style-type: none"> <li>• Flanged</li> <li>• Welded</li> </ul>	<ul style="list-style-type: none"> <li>• Flanged</li> <li>• Welded</li> </ul>
Body Materials*	<ul style="list-style-type: none"> <li>• Carbon Steel</li> <li>• Low Temperature Carbon Steel</li> <li>• Duplex</li> <li>• Stainless Steel</li> <li>• Incoloy 825</li> <li>• Inconel 625</li> </ul>	<ul style="list-style-type: none"> <li>• Carbon Steel</li> <li>• Low Temperature Carbon Steel</li> <li>• Duplex</li> <li>• Stainless Steel</li> <li>• Incoloy 825</li> <li>• Inconel 625</li> </ul>	<ul style="list-style-type: none"> <li>• Carbon Steel</li> <li>• Low Temperature Carbon Steel</li> <li>• Duplex</li> <li>• Stainless Steel</li> <li>• Incoloy 825</li> <li>• Inconel 625</li> </ul>	<ul style="list-style-type: none"> <li>• Carbon Steel</li> <li>• Low Temperature Carbon Steel</li> <li>• Duplex</li> <li>• Stainless Steel</li> <li>• Incoloy 825</li> <li>• Inconel 625</li> </ul>
Seat Materials*	<ul style="list-style-type: none"> <li>• Stainless Steel</li> <li>• Inconel</li> <li>• Duplex</li> <li>• Super Duplex</li> </ul>	<ul style="list-style-type: none"> <li>• Stainless Steel</li> <li>• Inconel</li> <li>• Duplex</li> <li>• Super Duplex</li> </ul>	<ul style="list-style-type: none"> <li>• Stainless Steel</li> <li>• Inconel</li> <li>• Duplex</li> <li>• Super Duplex</li> </ul>	<ul style="list-style-type: none"> <li>• Stainless Steel</li> <li>• Inconel</li> <li>• Duplex</li> <li>• Super Duplex</li> </ul>
Application & Options	<ul style="list-style-type: none"> <li>• Cryogenic</li> <li>• Oil and Gas transportation</li> <li>• High temperature</li> <li>• Tight shut-off requirements</li> </ul>	<ul style="list-style-type: none"> <li>• Moderate control</li> <li>• Chemical and Petrochemical applications</li> <li>• Tight shut-off requirements</li> </ul>	<ul style="list-style-type: none"> <li>• Antisurge application</li> <li>• Hp/Ip/Lp drain and vent application</li> <li>• Tight shut-off requirements</li> </ul>	<ul style="list-style-type: none"> <li>• Depressurizing and blow-down service</li> <li>• Cavitation control</li> <li>• Noise reduction</li> <li>• High rangeability</li> <li>• Cryogenic and high temperature service control</li> <li>• Self-cleaning, non clogging</li> </ul>





Hyper Cage	Hyper Cage Multistage	Hyper Silent	Cage Ball Orifice Plate	Inline Choke Ball
Pigable version Full and Reduced Bore	High Performance Full and Reduced Bore	High Noise Control Full and Reduced Bore	High Performance Full and Reduced Bore	Choke Conditions High Performance Full and Reduced Bore
6÷60" DN 150÷1500	6÷60" DN 150÷1500	6÷60" DN 150÷1500	6÷60" DN 150÷1500	1÷8" DN 25÷200
ASME Class 150÷2500# API 10000÷20000	ASME Class 150÷2500# API 10000÷20000	ASME Class 150÷2500# API 10000÷20000	ASME Class 150÷2500# API 10000÷20000	ASME Class 150÷2500# API 10000÷20000
<ul style="list-style-type: none"> <li>• Flanged</li> <li>• Welded</li> </ul>	<ul style="list-style-type: none"> <li>• Flanged</li> <li>• Welded</li> </ul>	<ul style="list-style-type: none"> <li>• Flanged</li> <li>• Welded</li> </ul>	<ul style="list-style-type: none"> <li>• Flanged</li> <li>• Welded</li> </ul>	<ul style="list-style-type: none"> <li>• Flanged</li> <li>• Welded</li> </ul>
<ul style="list-style-type: none"> <li>• Carbon Steel</li> <li>• Low Temperature Carbon Steel</li> <li>• Duplex</li> <li>• Stainless Steel</li> <li>• Incoloy 825</li> <li>• Inconel 625</li> </ul>	<ul style="list-style-type: none"> <li>• Carbon Steel</li> <li>• Low Temperature Carbon Steel</li> <li>• Duplex</li> <li>• Stainless Steel</li> <li>• Incoloy 825</li> <li>• Inconel 625</li> </ul>	<ul style="list-style-type: none"> <li>• Carbon Steel</li> <li>• Low Temperature Carbon Steel</li> <li>• Duplex</li> <li>• Stainless Steel</li> <li>• Incoloy 825</li> <li>• Inconel 625</li> </ul>	<ul style="list-style-type: none"> <li>• Carbon Steel</li> <li>• Low Temperature Carbon Steel</li> <li>• Duplex</li> <li>• Stainless Steel</li> <li>• Incoloy 825</li> <li>• Inconel 625</li> </ul>	<ul style="list-style-type: none"> <li>• Carbon Steel</li> <li>• Low Temperature Carbon Steel</li> <li>• Duplex</li> <li>• Stainless Steel</li> <li>• Incoloy 825</li> <li>• Inconel 625</li> </ul>
<ul style="list-style-type: none"> <li>• Stainless Steel</li> <li>• Inconel</li> <li>• Duplex</li> <li>• Super Duplex</li> </ul>	<ul style="list-style-type: none"> <li>• Stainless Steel</li> <li>• Inconel</li> <li>• Duplex</li> <li>• Super Duplex</li> </ul>	<ul style="list-style-type: none"> <li>• Stainless Steel</li> <li>• Inconel</li> <li>• Duplex</li> <li>• Super Duplex</li> </ul>	<ul style="list-style-type: none"> <li>• Stainless Steel</li> <li>• Inconel</li> <li>• Duplex</li> <li>• Super Duplex</li> </ul>	<ul style="list-style-type: none"> <li>• Stainless Steel</li> <li>• Inconel</li> <li>• Duplex</li> <li>• Super Duplex</li> </ul>
<ul style="list-style-type: none"> <li>• High range of process conditions</li> <li>• Negligible ΔP at full stroke</li> <li>• Tight shut-off requirements</li> </ul>	<ul style="list-style-type: none"> <li>• Low noise</li> <li>• Cavitation control</li> <li>• Velocity and vibration control</li> <li>• High capacity and rangeability</li> <li>• Tight shut-off requirements</li> </ul>	<ul style="list-style-type: none"> <li>• High capacity of noise control</li> <li>• Flow and pressure control</li> <li>• Tight shut-off requirements</li> </ul>	<ul style="list-style-type: none"> <li>• Pressure equalization</li> <li>• High ΔP</li> <li>• Flow and pressure control</li> <li>• Tight shut-off requirements</li> </ul>	<ul style="list-style-type: none"> <li>• Choke applications</li> <li>• Tight shut-off requirements</li> </ul>

\* others on request



# Calculation Program

## SimOne™

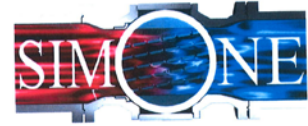

“SimOne” is Pibiviesse’s proprietary simulation program for control valve sizing and valve behavior prediction.

The “SimOne” sizing software is the new control valve sizing program based not only on calculation equations, but also on Pibiviesse’s experience in the field. As the interpretation of results and the interactive platform it will be continuously developed. Our

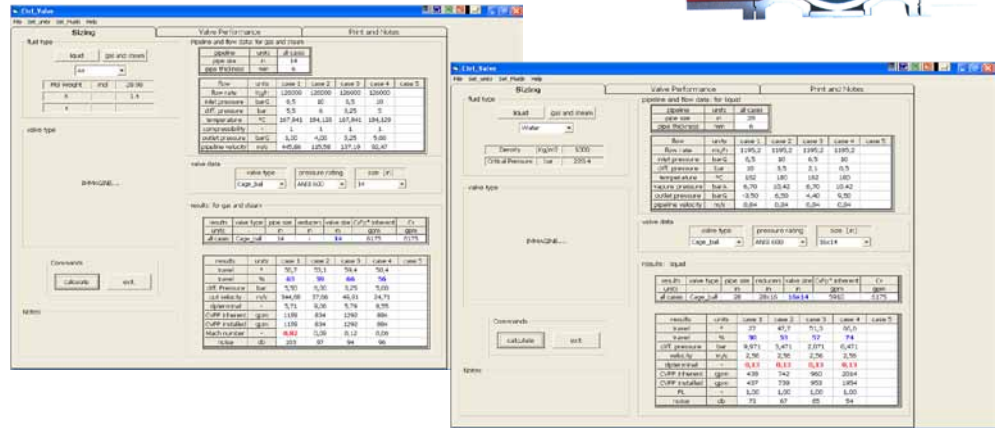

purpose is to let you know how Pibiviesse is working and moving in the control valve field. An estimated noise level evaluated in accordance with VDMA 24422 or IEC 60534-8-4. The “SimOne” has been developed to work on Microsoft Windows Xp, 2000, ME, NT4, 98 operating system based on the Intel Architecture platform. Pibiviesse has developed “SimOne” in cooperation with the Technical University of Milan, the program is available for Customers upon request.

## Flow Lab

With the aim of testing the experimental characterization of control valves, a test facility, named TestOne, has been installed at Pibiviesse. It is a flow loop, projected following the ISARP75.23-1995 normative, that allow Pibiviesse to make experimental measurements on valves.

This facility has been projected with the cooperation of the Politecnico di Milano University. The loop is made by a tank containing water and glycol (about 30%), a centrifugal pump with variable frequency of rotation (from 20 Hz up to 45 Hz) and a drain valve (a full bore type) situated immediately upstream the tank and downstream the tested valve. Varying both, the frequency of rotation of the pump, and the travel rate of the drain valve, it is possible to change the boundary conditions of the tests.

The choice to use a vertical configuration and to place the test valves on the top side of the loop makes easier to reach the cavitation conditions.

Following the same philosophy, in the PIBIVIESSE factory, we are performing a new facility, named Air Lab, useful to study the behavior of valves with gas flows.

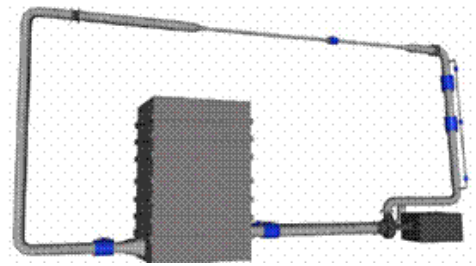

*TestOne equipment  
Qualification ISARP75.23.-1995*

### Loop Functional Features

#### Pump Characteristic

- Maximum Allowable
- Frequency: 45 Hz
- Maximum Head: 80 meters

#### Available Measures:

- Flow rate
- Pressure
- Temperature
- Acceleration
- Sound Pressure Level





# Quality assurance system

The high consideration given by management to quality and its control has been one of the main factors to determine the success of PIBIVIESSE. All our manufacturing operations are covered by a quality assurance program, which has been audited and qualified in accordance with:



**API 6D - ISO 14313**

**ISO 9001 - 2000 & API Q1**



**API 6A - ISO 10423**

**GOST**



**PED 97/23/EC**



**API 17D**

**SIL II, III**

PIBIVIESSE has been authorised to use the API 6A, 6D, 17D monograms and to manufacture its products with CE logo in accordance with Pressure Equipment Directive 97/23/EC since June 2001. The full production range is therefore available with CE marking and ATEX certificate of conformity.

# Pibiviesse in the world

## A World of Servicing

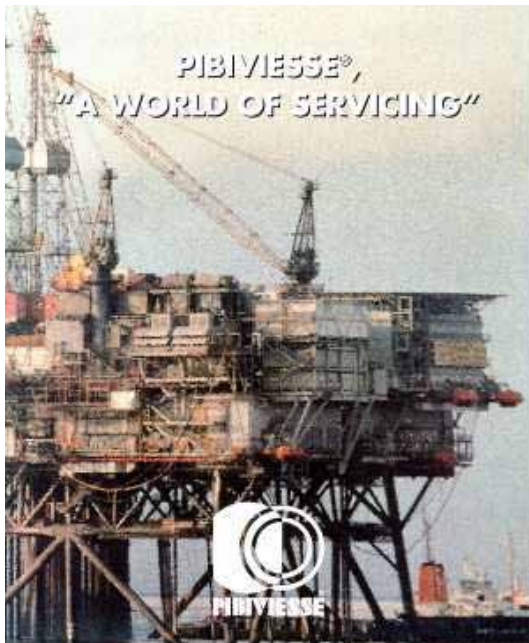

PIBIVIESSE has a world-wide network of Authorised Repair Workshops that are trained by our After Sales Service Department to provide customer assistance on all our products.

## References and approvals

PIBIVIESSE has been audited and approved by many of the major worldwide Engineering Companies, Contractors, Oil Companies, Oil and Gas Pipeline Authorities and is supplying valves for many different and demanding service conditions for off-shore and on-shore applications. Please contact our offices for specific references and approvals.

### **Pibiviesse valves have been installed in the following countries:**

Algeria, Australia, Belgium, Brasil, Canada, Caspian sea area, China, Ecuador, Egypt, France, Germany, Greece, Holland, India, Indonesia, Iran. Italy, Kazahstan, Libya, Malesia, Mexico, New Zealand, Nigeria, Norway, Pakistan, Philippines, Portugal, Saudi Arabia, South Africa, South Korea, Spain, Sudan, Syria, Taiwan, Thailand, Turkey, United Arab Emirates, United Kingdom, USA, Uzbekistan, Venezuela, Vietnam







Continuously Improving Flow Control. Worldwide.



PIBIVESSE S.r.l.  
20014 NERVIANO (Milano)  
Via Bergamina, 24 - ITALY  
Phone +39 0331 408711  
Fax +39 0331 408802  
info@pibiviesse.it

[www.pibiviesse.it](http://www.pibiviesse.it)