

Type TDM

Pump protection valve for centrifugal pumps

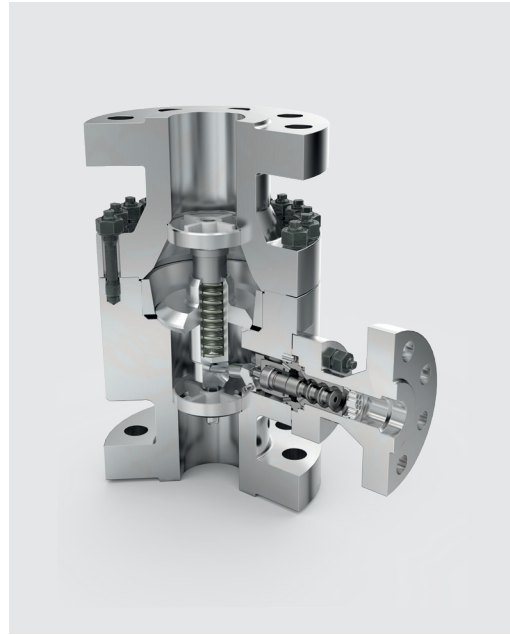

> Type TDM, front view



> Type TDM, sectional view

Product features

- Automatically modulating bypass function
- Forged housing material, carbon steel or stainless steel
- Special materials possible (e.g. Super Duplex)
- Internal operation (no external energy source required)
- Easy to install
- Low maintenance
- Suitable for all liquids

Applications

- Boiler feed water
- Condensate
- Chemical processes
- Extinguishing water
- Snow canons

Type TDM

Pump protection valve for centrifugal pumps

Technical data

Nominal diameter	DN 25–300 / NPS 1–12
Pressure class	PN 63–400 / Class 150–2500
Temperature (max.)	Up to 230 °C / 446 °F (other temperatures on request)
Housing material	1.0460 / A105 1.0571 / LF2 1.4404 / F316L 1.4462 / F51 1.4501 / F55
Housing type	Forged
Media	Liquids of all kinds (water, oils, chemicals and others)
Flanges	EN 1092-1, ASME B16.5, ISO 7005, JIS, JPI, welding ends on request
Designs	Vertical installation, horizontal installation, manual start-up, enlarged nominal width of the bypass, degassing connection
Number of stages (max.)	5
Number of controlled stages (max.)	5
Operating range (max.)	Delta p up to max. 230 bar
Other	Bypass differential pressure 20–230 bar

Type TDM

Pump protection valve for centrifugal pumps

Function

The outlet main flow controls the non-return valve and positions it in proportion to the flow. The stem of the non-return valve transmits the motion via a lever to the bypass. The bypass system regulates the bypass flow in a modulating way and reduces the pressure to the bypass outlet pressure level without cavitation.

When the non-return valve is completely closed, the entire minimum flow is routed through the bypass. The bypass is fully closed when the non-return valve is in its upper position, thereby allowing full pump flow to the system.

Flow sensitive modulating bypass control

The non-return valve moves upwards with increasing main flow and downwards with decreasing flow. The non-return valve transmits this movement to the control lever.

The movement of the lever is transmitted via a piston to the multi-stage vortex plug. The minimum flow is then bypassed in a modulating way over several pressure reduction stages.

The TDM can be used for differential pressures from 20 bar up to 230 bar. The standard TDM design has a built-in bypass non-return function (~2 bar dp level required).

Manual bypass options for TDM valves

Depending on the plant design or additional requirements, various options can be selected for the start-up / warm-up side (A) and for the bypass side (B).

Option A:

One frequently used option is to feed low pressure flow to the process / boiler via the manual start-up. Either for the warm-up process or for heating the adjacent pumps/systems.

Option B:

Depending on the operating conditions of the system (dirt, certain load cases, etc.), special internal parts can be selected for the bypass. The valve is then supplied with the integrated optional bypass set. In this case the original internal parts for the bypass are supplied and installed after commissioning.

Type TDM

Pump protection valve for centrifugal pumps

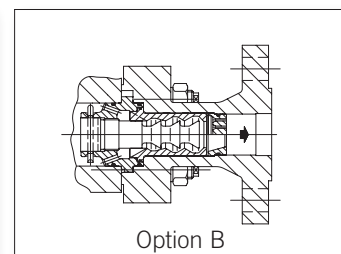
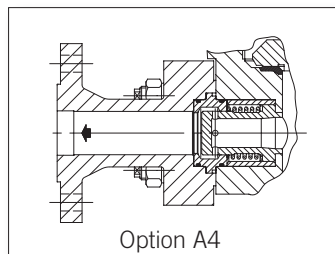
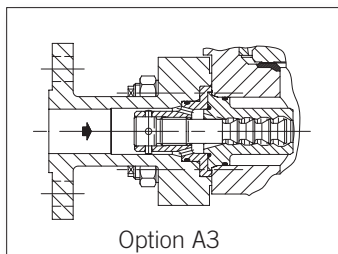
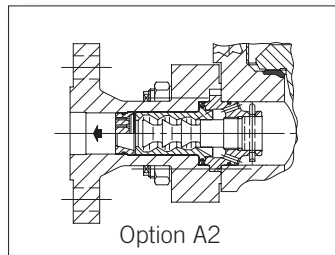
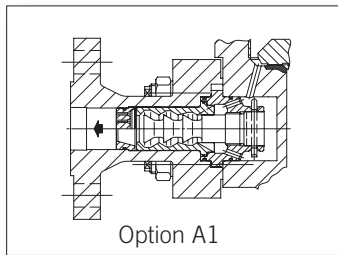
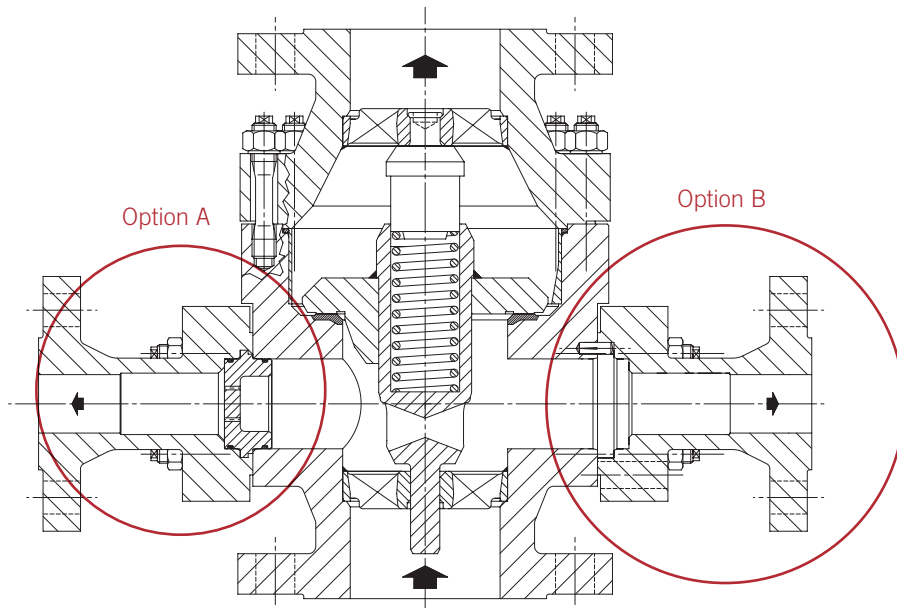

Option A1 - Start-up/heating connection above the non-return valve

Option A2 - Start-up/heating connection under the non-return valve

Option A3 - Heating under the non-return valve

Option A4 - Degassing system

Option B - Commissioning internal parts for the TDM valve

Type TDM

Pump protection valve for centrifugal pumps

Installation information

The TDM valve should be installed as close as possible to the discharge port of the centrifugal pump, preferably directly on the pump discharge port of the pump.

To avoid frequency interference due to pressure oscillations in the medium, the distance between the pump outlet and the valve inlet should not exceed 3 m. Take care to ensure a straight inlet section. Exceptions have to be confirmed to SCHROEDAHL.

Vertical installation is preferred, but horizontal installation is also possible upon request. TDM valves operate at a low noise level and ensure a high reliability due to their sturdy design.

The recommended filter at the pump inlet should have a mesh size of 0.3 to 0.5 mm. A smaller mesh size of 0.1 mm is recommended for commissioning.

Type TDM

Pump protection valve for centrifugal pumps

Sectional drawing (housing)

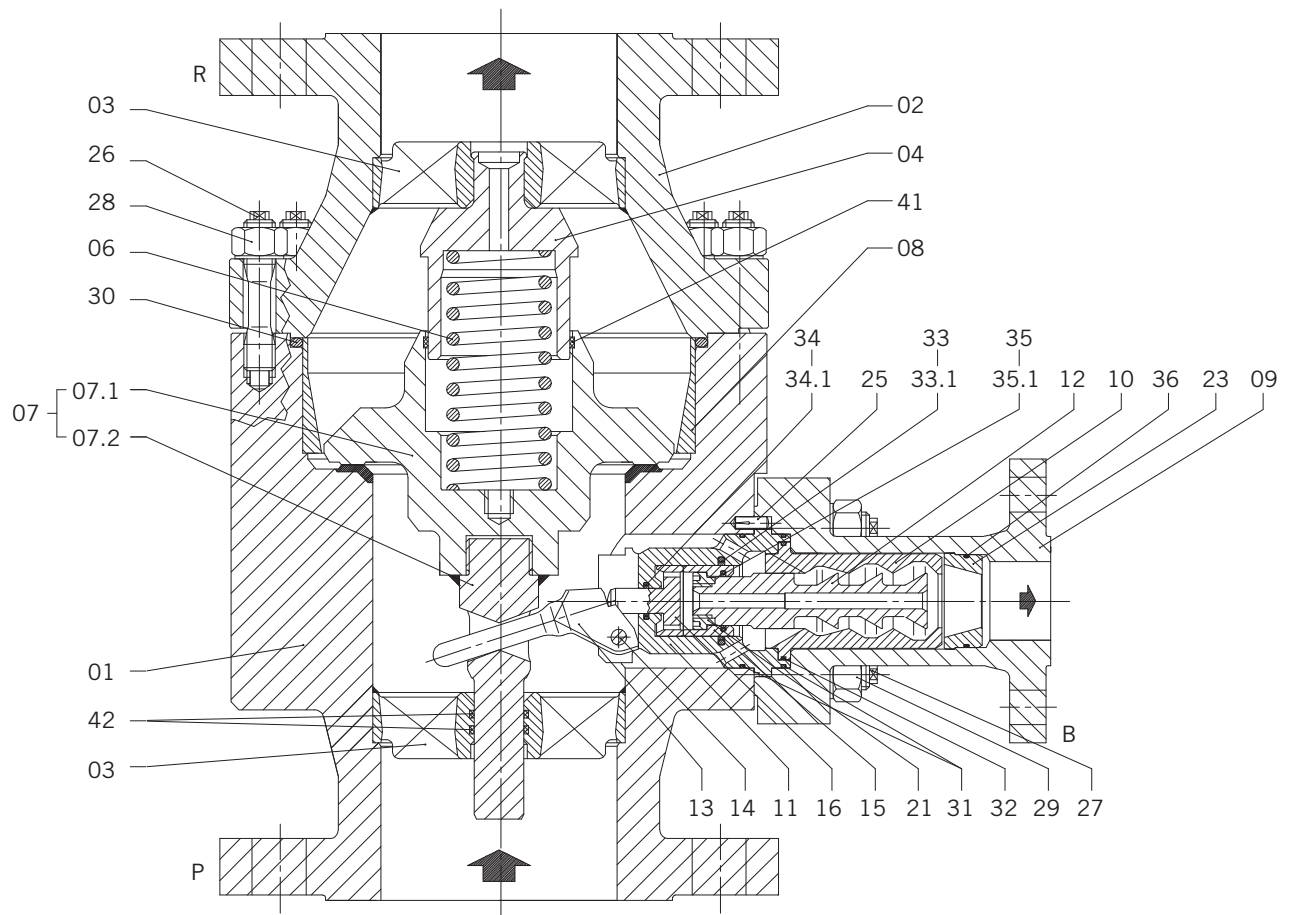

Type TDM

Pump protection valve for centrifugal pumps

Parts list (housing)

Pos.	Item	Material
01	Lower body	*
02	Upper body	*
03	Stemguide	1.4408
03.1	Stemguide	1.4408
04	Guide bolt	1.4021
06	Spring	1.4310
07	Check valve cpl.	1.4404
07.1	Check valve	1.4404
07.2	Stem	1.4404
08	Liner or venturi ring	1.4300 o. 1.4301
09	Bypass branch	*
25	Guide pin	A2
26	Bolt	**
27	Bolt	**
28	Hexagon nut	**
29	Hexagon nut	**
30	O-Ring	*
41	Ring	PTFE/Carbon
42	Guide ring	PTFE/Carbon

 Recommended spare/wear parts

* Depending on customer requirements

** Depending on size and pressure rating

Parts list as an example of the standard configuration

Type TDM

Pump protection valve for centrifugal pumps

Sectional drawing (bypass)

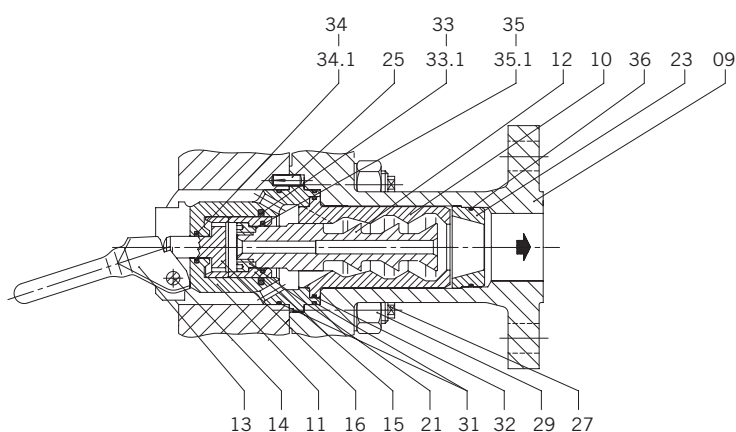

Parts list (bypass)

Pos.	Item	Material
10	Vortex bushing	1.4122
11	Control head	1.4122
12	Vortex plug	1.4122
13	Lever	1.4313
14	Pivot pin	1.4021
15	Relief bushing	1.4122
16	Relief piston	1.4122
21	Threaded ring	1.4122
23	Orifice bushing / nozzle	1.4122
31	O-Ring	*
32	O-Ring	*
33	O-Ring	*
33.1	Glyd ring	PTFE/Carbon
34	O-Ring	*
34.1	Glyd ring	PTFE/Carbon
35	O-Ring	*
35.1	Glyd ring	PTFE/Carbon
36	O-Ring	*

 Recommended spare/wear parts

* Depending on customer requirements

Parts list as an example of the standard configuration

Type TDM

Pump protection valve for centrifugal pumps

Sectional drawing (manual start-up)

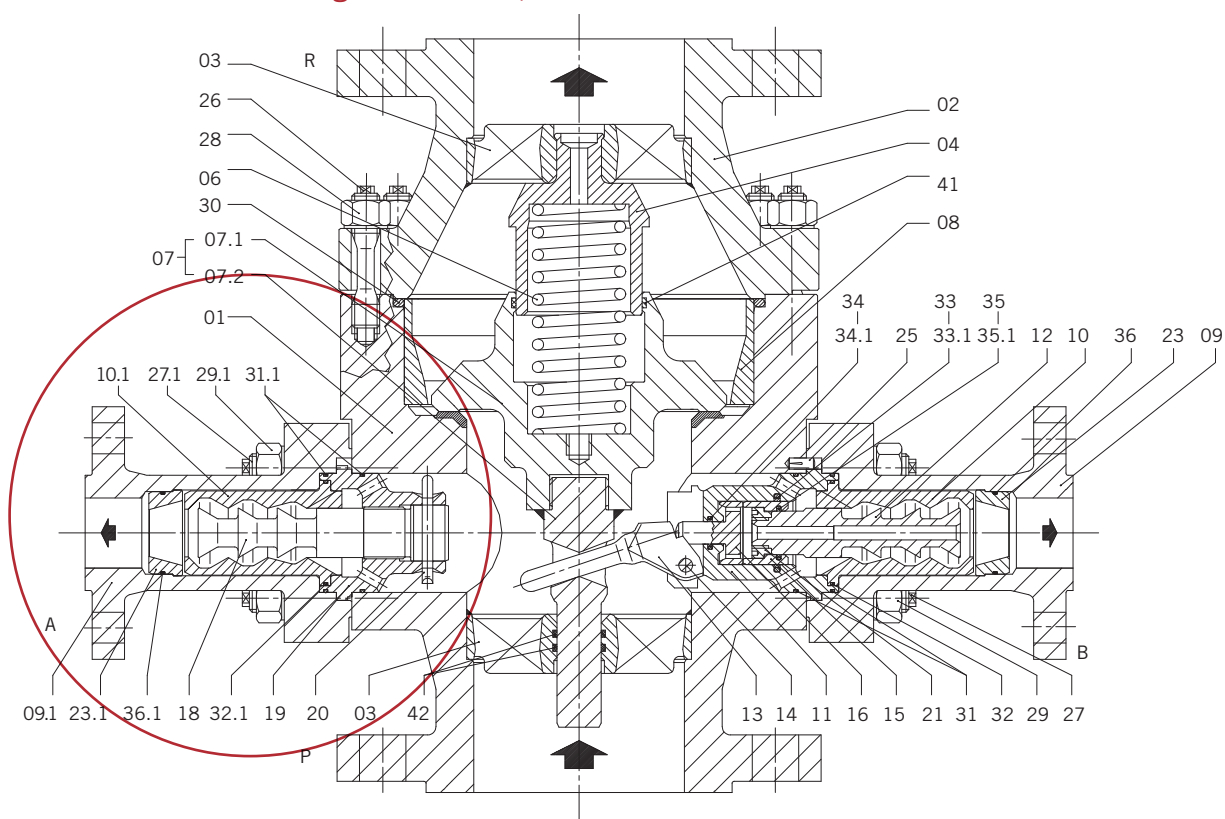

Parts list (manual start-up)

Pos.	Item	Material
09.1	Bypass branch	*
10.1	Vortex bushing	1.4122
18	Start-up vortex plug	1.4122
19	Holder	1.4122
20	Pin	1.4300
23.1	Orifice bushing / nozzle	1.4122
27.1	Bolt	**
29.1	Hexagon nut	**
31.1	O-Ring	*
32.1	O-Ring	*
36.1	O-Ring	*

 Recommended spare/wear parts

* Depending on customer requirements

** Depending on size and pressure rating

Parts list as an example of the standard configuration

Type TDM

Pump protection valve for centrifugal pumps

Dimensions EN

DN _R / DN _P	PN	DN _B	Type	L (mm)	S (mm)	H (mm)	Weight (kg)
25	63-160	15	055-057	250	190	90	30
32	63	25	065	250	190	90	30
	100		066	250	190	90	30
40	63-100-160	25	075-076-077	260	190	90	35
	250		078	300	215	120	50
50	63	25	085	300	185	115	50
	100-160		086-087	300	193	110	60
	250		088	350	223	130	85
65	63	40	095	340	219	125	60
	100-160		096-097	340	227	125	85
	250		098	400	260	145	90
80	63	40	105	380	233	140	70
	100-160		106-107	380	240	140	85
	250		108	450	265	165	125
	320		109	510	300	185	180
100	63	50	115	430	258	155	105
	100-160		116-117	430	266	155	150
	250		118	520	300	190	200
125	63	50	125	500	280	175	185
	100-160		126-127	500	291	175	225
	250		128	600	321	215	345
	320		129	710	390	250	450
	400		120	780	420	290	580
150	63	65	135	550	350	190	255
	100		136	550	355	190	270
	160		137	585	355	200	275
	250		138	700	405	250	480
	320		139	805	400	270	770
	400		130	850	500	315	900
200	63	80	155	650	405	215	470
	100-160		156-157	680	430	225	550
	250		158	830	485	290	950
	320		159	910	515	340	1200
	400		150	1150	600	410	1700
250	63	100	165	775	520	260	700
	100-160		166-167	775	560	260	1000
	250		168	900	560	310	1500
300	63	125	175	900	550	300	950
	100-160		176-177	1050	650	360	1600
	250		178	1200	720	420	2100

Type TDM

Pump protection valve for centrifugal pumps

Dimensions ASME

DN _R / DN _P	PN	DN _B	Type	L (mm)	S (mm)	H (mm)	Weight (kg)
NPS 1	300	NPS 1	055	250	190	90	30
	600		055	250	190	90	30
	900		057	310	200	120	40
	1500		058	320	215	130	50
NPS 1,25	300	NPS 1	065	250	190	90	30
	600		066	250	190	90	30
	900		067	310	200	120	40
	1500		068	320	215	130	50
NPS 1,5	300	NPS 1	075	260	190	90	35
	600		076	260	190	90	35
	900		077	300	200	110	35
	1500		078	310	215	120	50
NPS 2	300	NPS 1	085	300	185	115	50
	600		086	300	193	110	60
	900		087	340	203	130	60
	1500		088	350	233	130	85
NPS 2,5	300	NPS 1,5	095	340	199	125	60
	600		096	340	220	125	85
	900		097	380	230	140	85
	1500		098	400	250	145	90
NPS 3	300	NPS 1,5	105	380	220	140	70
	600		106	380	240	140	85
	900		107	410	250	150	85
	1500		108	450	275	165	125
NPS 4	300	NPS 2	115	430	240	155	105
	600		116	430	266	155	150
	900		117	450	280	160	150
	1500		118	520	300	190	200
NPS 5	300	NPS 2	125	500	290	175	185
	600		126	500	300	175	225
	900		127	525	310	185	225
	1500		128	650	341	235	345
	2500		120	780	420	290	580
NPS 6	300	NPS 2,5	135	550	350	190	255
	600		136	550	355	190	270
	900		137	585	355	200	275
	1500		138	700	405	250	480
	2500		130	850	500	315	900

Type TDM

Pump protection valve for centrifugal pumps

DN _R / DN _P	PN	DN _B	Type	L (mm)	S (mm)	H (mm)	Weight (kg)
NPS 8	300	NPS 3	155	650	405	215	470
	600		156	680	430	225	550
	900		157	700	430	225	550
	1500		158	880	485	310	950
	2500		150	1150	600	410	1700
NPS 10	300	NPS 4	165	775	520	260	700
	600		166	800	560	270	1000
	900		167	800	560	270	1000
	1500		168	980	570	340	1500
	2500		160	1420	650	500	1600
NPS 12	300	NPS 5	175	900	550	300	950
	600		176	1050	650	360	1600
	900		177	1050	650	360	1600
	1500		178	1250	720	440	2100
NPS 14	300	NPS 6	185	1100	640	340	1360
	600		186	1100	650	350	1510